

Order Form

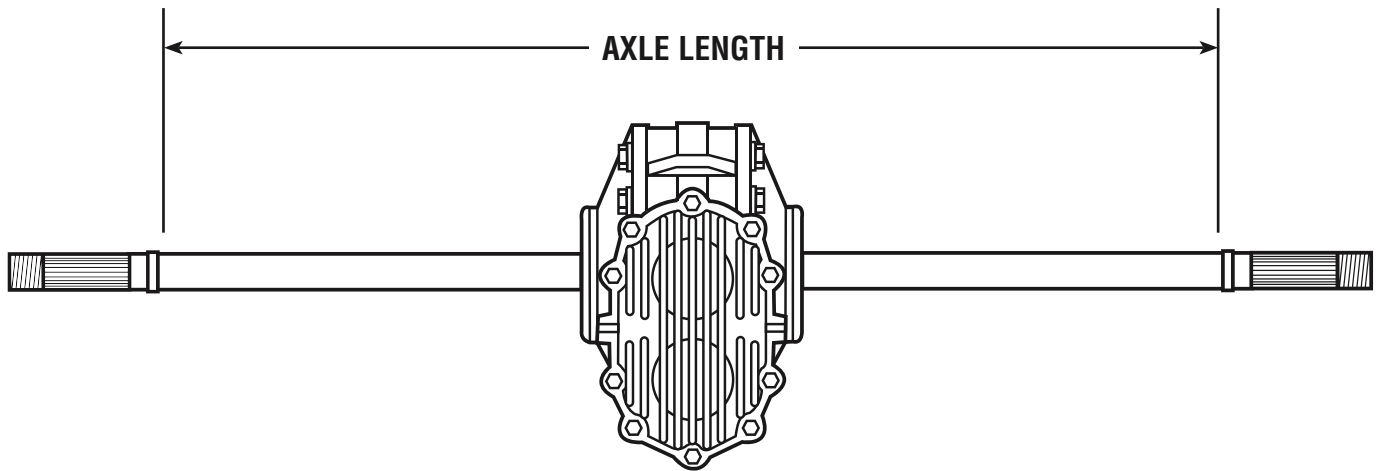

8300 Lane Drive • Watervliet, MI 49098
Phone: (269) 463-4113 Fax: (269) 463-6708

WINTERS OPEN TUBE LIVE AXLE ORDER FORM



K 637 _____
AXLE LENGTH _____
OFFSET _____

K 837 _____
RING & PINION _____
STANDARD COUPLER _____
INTERNAL COUPLER _____

STANDARD OPTIONS INCLUDE: 8104, 8106, 8122, 8137, 8141 & 8143

OPTIONS:

Customer Name: _____

Customer Number: _____

Customer PO Number: _____

Customer Representative: _____

Date: _____



Custom Order Release

Please be advised that in placing this order for custom manufactured merchandise you are accepting full responsibility for the correctness and accuracy of all pertinent ordering information. Further, be advised that by filling out and signing this form you are affirming the correctness and accuracy of the information contained herein and authorizing Motor State Distributing to order this custom merchandise. Once this form has been signed, the purchaser assumes full responsibility for paying for the custom merchandise and no refund will be issued unless it can be shown that any errors or defects were the fault of the manufacturer and not caused by erroneous information.

As a rule, custom orders cannot be cancelled once the order is placed with the manufacturer. All custom orders are subject to freight and handling charges from the manufacturer.

No returns will be accepted on custom-built items.

Sales Contact At Motor State _____

Customer Number _____

Company Name _____

Address _____

City _____ State _____ Zip _____

Phone _____

Fax _____

Email _____

Print Your Name _____ Date _____

Authorized Signature _____

If you are submitting this form electronically, your digital signature must be added last. Once signed, this form becomes non-editable. Please double check all items first.

Motor State Distributing

8300 Lane Drive, Watervliet MI 49098

web: www.motorstate.com | phone: 1-800-772-2678 | fax: 1-800-772-2618